

SUBMITTAL
EXAMPLE

HVAC TRAP DESIGN & MAINTENANCE

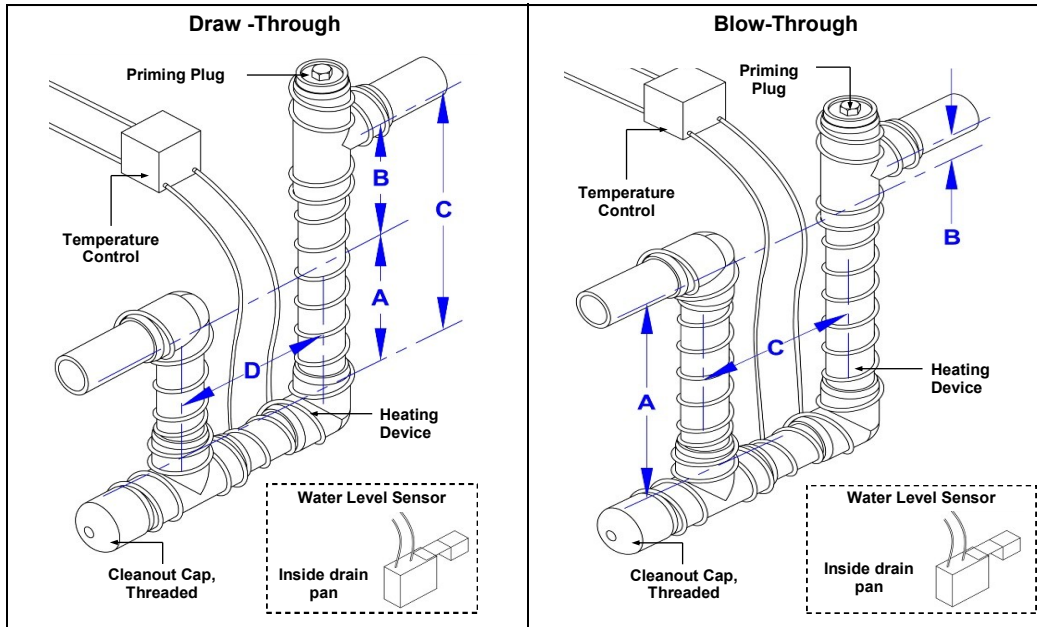

Prepared by:

Warren C. Trent PE

Trent Technologies, Inc.

15939 Old Jacksonville Highway, Tyler, TX 75703

903-509-4843

info@TrentTech.com

www.TrentTech.com

VIDEO

[Understanding HVAC Condensate Traps](#)



© ***Trent Technologies, Inc.***

HVAC TRAP DESIGN & MAINTENANCE

BACKGROUND

General

One primary function of the air conditioning system is to dehumidify the air by removing water as it passes through the air handler. Collected in a drain pan below the cooling coil, as illustrated in **Figure 1**, the water must be removed to prevent damage and contamination to the air handler system and

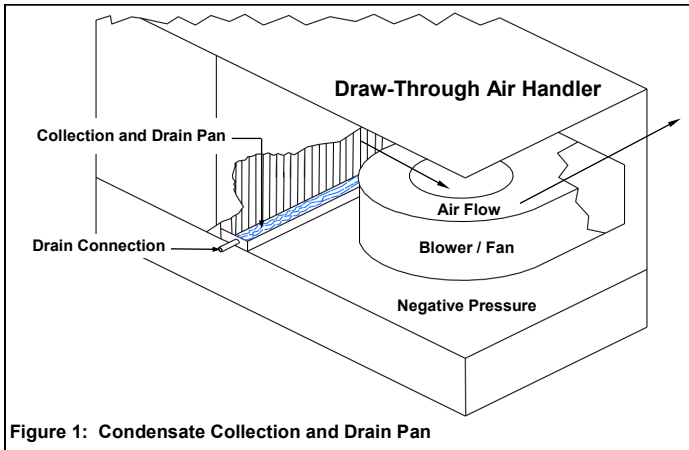

Figure 1: Condensate Collection and Drain Pan

building. Draining water from a condensate drain pan is not a simple process. The blower that forces air through the system creates a pressure in the drain pan compartment, which adversely affects condensate removal. When the blower is located downstream of the cooling coil, the pan pressure is negative (below ambient) and when located upstream of the cooling coil, the pan pressure is positive (above ambient). These systems, referred to as draw-through and blow-through systems, respectively, require special provisions to allow condensate drainage. Failure to provide successful condensate drainage causes a multitude of health and property damage issues.

Without special provisions for draining, the negative pressure in draw-through systems causes water to stand in the drain pan and can cause destructive condensate overflow. Air ingested through the drain opening entrains condensate and spreads it onto internal components where it supports the growth of unhealthy organisms. In addition, the ingested air may be noxious and toxic.

Without special provisions for draining, the positive pressure in blow-through drain systems aids the drainage of condensate, but the exhausting air entrains condensate and blows it onto floors, walls, and other components where it can cause damage and present health and safety problems.

Current Drain Systems

Condensate drain systems accepted as the “industry standard” include water traps, like the one shown in **Figure 2**. Properly designed and maintained, trapped systems can provide successful condensate drainage. However, within the industry there is no definition of what constitutes proper or acceptable design.

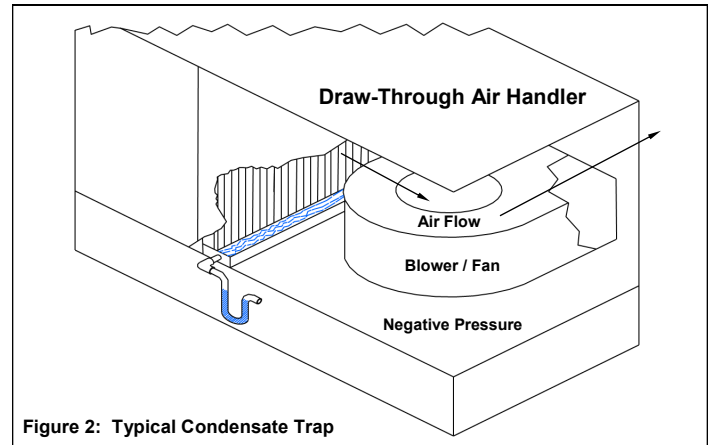

Figure 2: Typical Condensate Trap

The problems caused by condensate traps are well known by many in the industry. For example, ASHRAE Standard 62-89R includes the following paragraph:

“Condensate traps exhibit many failure modes that can impact on indoor air quality. Trap failures due to freeze-up, drying out, breakage, blockage, and/or improper installation can compromise the seal against air ingestion through the condensate drain line. Traps with insufficient height between the inlet and outlet [design deficiency] on draw-through systems can cause the drain to back-up when the fan is on, possibly causing drain pan overflow or water droplet carryover into the duct system. The resulting moist surfaces can become sources of biological contamination. Seasonal variations, such as very dry or cold weather, may adversely affect trap operation and condensate removal.”

Two national mechanical and plumbing codes, International and Uniform, do nothing to prevent the failures described in the ASHRAE Standard. They simply state that drain systems must be trapped, leaving design to others. The traps like those shown in **Figure 3** are available at many HVAC supply houses. They meet the codes and are often used in drain systems, regardless the drain pan pressure and type of air handler.

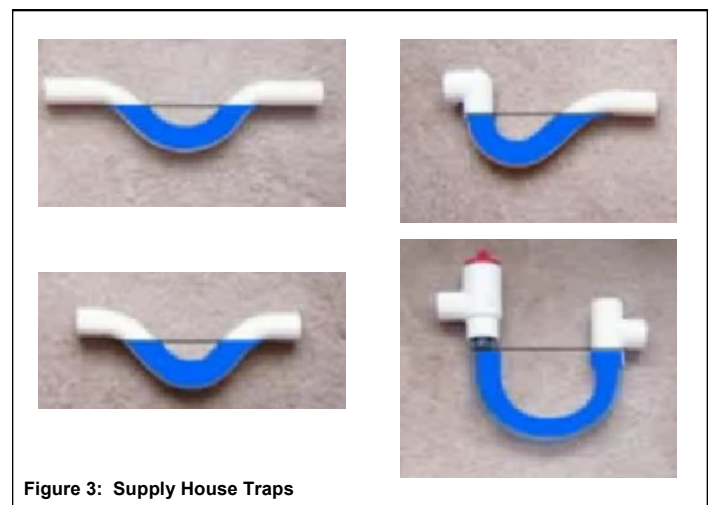
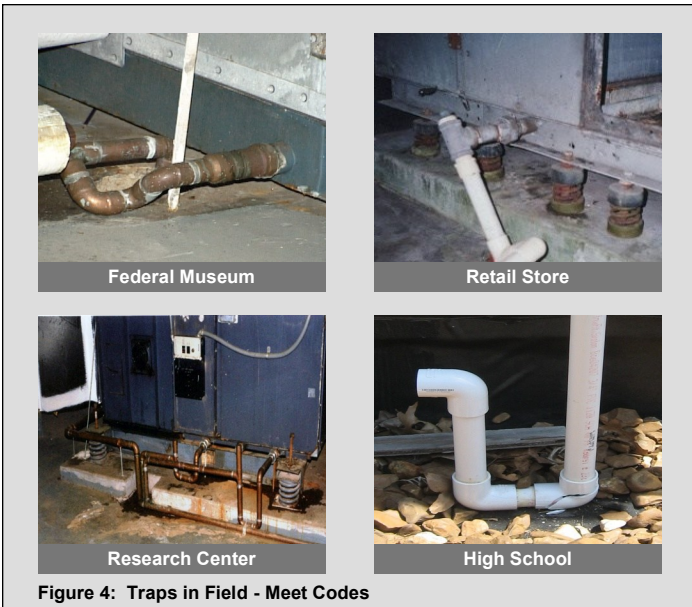

Figure 3: Supply House Traps



In the field today, few air conditioning systems are free of the undesirable conditions described in ASHRAE Standard 62-89R. Typical drain systems found in the field are shown in **Figure 4**.

Systems with these traps satisfy codes and general practices, but are unsuitable for condensate drainage. The consequences of failed drain systems are shown in **Figures 5 and 6**.

These conditions are common and well recognized by many members of the air conditioning industry. But the problem gets little attention because failures are generally, erroneously, attributed to lack of maintenance by the building owner. In reality both maintenance and trap system design are at fault. Moreover, the trap geometry is often so deficient that the systems are virtually impossible to maintain.

Acceptable Drain System Design

The drain system design features necessary for acceptable condensate trap performance include: geometry dimensions that match the drain pan pressure; provisions for priming and debris cleanout; means for preventing drain pan overflow (to protect against untimely flow blockage); and a method for preventing trap freeze-up in sub-freezing environments. Designs that illustrate these features are shown in **Figures 7 and 8**, for draw-through and blow-through air handlers, respectively.

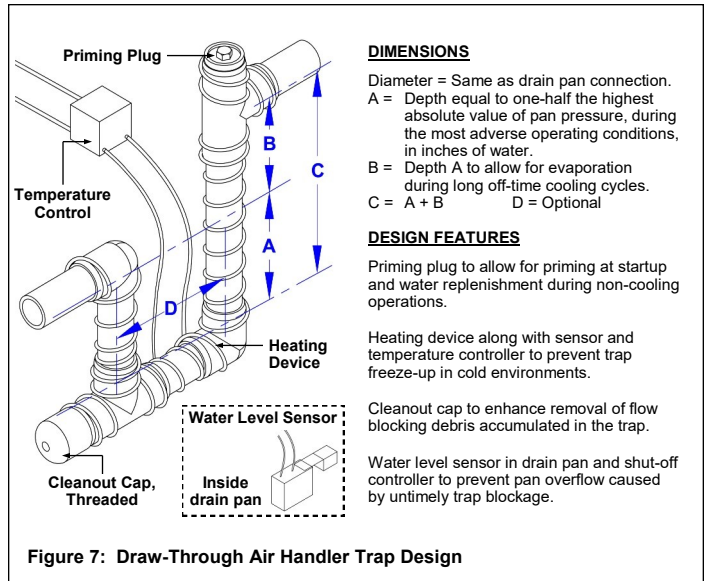

Figure 7: Draw-Through Air Handler Trap Design

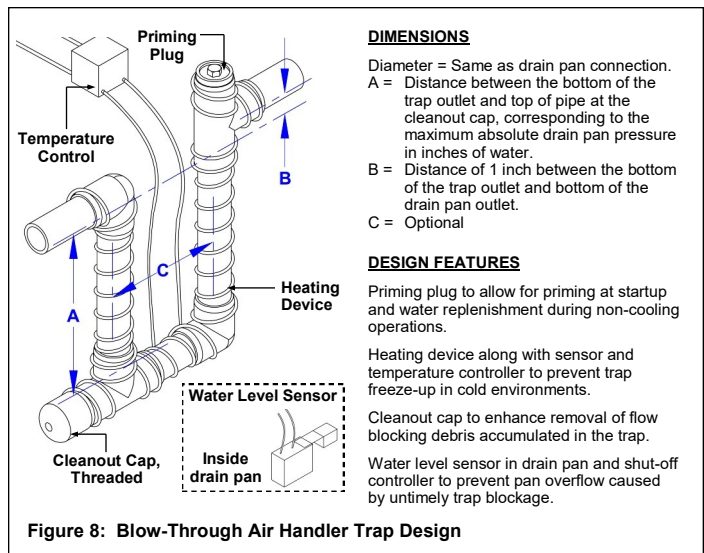
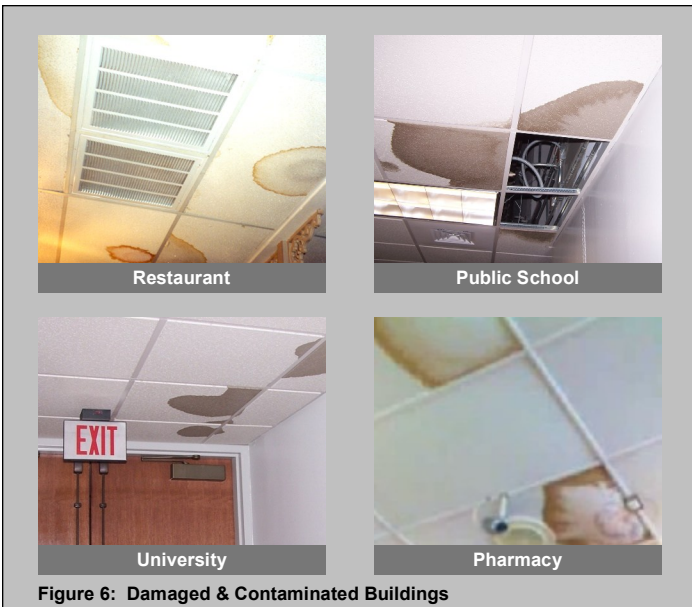

Figure 8: Blow-Through Air Handler Trap Design

Acceptable Drain System Installation

Installation of the acceptable trap system is the same as installing the “industry standard” system if freeze-up and pan overflow protection are provided. **Figures 9 through 12** illustrate installations in draw-through and blow-through air handlers. The trap heating device and the water level system are installed in accordance with the manufacturer’s installation instructions.

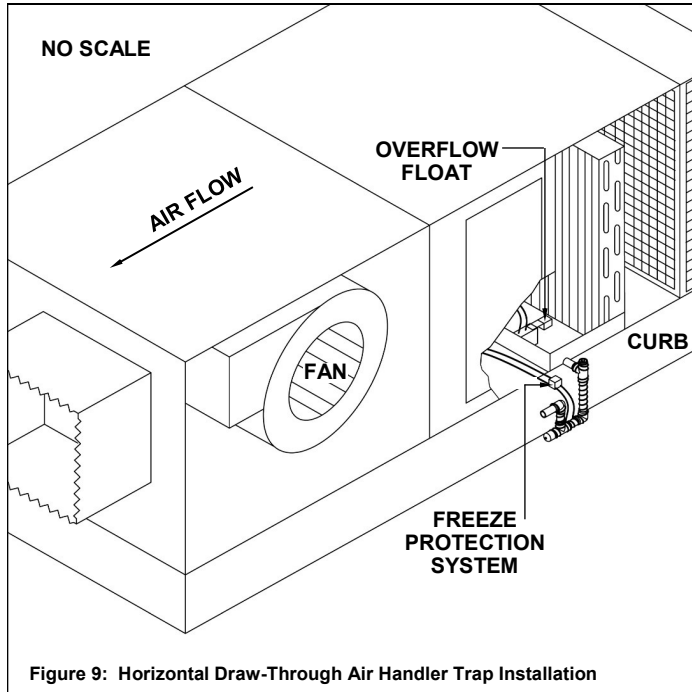

Figure 9: Horizontal Draw-Through Air Handler Trap Installation

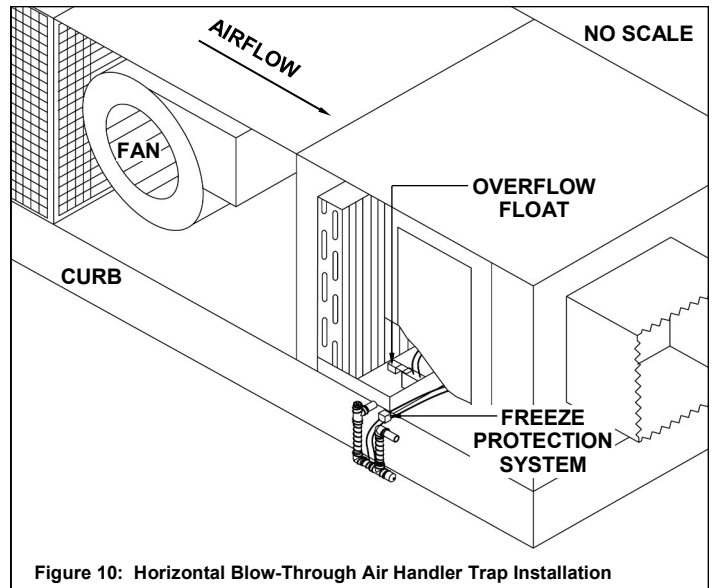

Figure 10: Horizontal Blow-Through Air Handler Trap Installation

Acceptable Drain System Maintenance

The maintenance effort required for an acceptable trap system for each type of air handler, draw-through and blow-through, include:

Priming:

- Add water annually at startup for summer cooling.
- Add water monthly or semi-monthly during winter as needed. In freezing environments, fill with anti-freeze during winter (units without heating provisions).

Heating Device:

- Check annually - prior to winter onset
 - heating device for damage
 - electrical circuit continuity; control relay operation and temperature sensor operation
- Replace failed components (moving and failure-prone parts).

Cleanout:

- Clean out algae and other debris - annually; semi-annually; or more often in hot and humid climates.
- Add biocide tablets to drain pan and trap if needed.

Water Level Controller:

- Check annually - at summer start-up
 - water float operation
 - electrical circuit continuity; control relay operation and temperature sensor operation
- Replace failed components (moving and failure-prone parts).

[Routine and Preventive Maintenance Program for Conventional Condensate Trap](#)

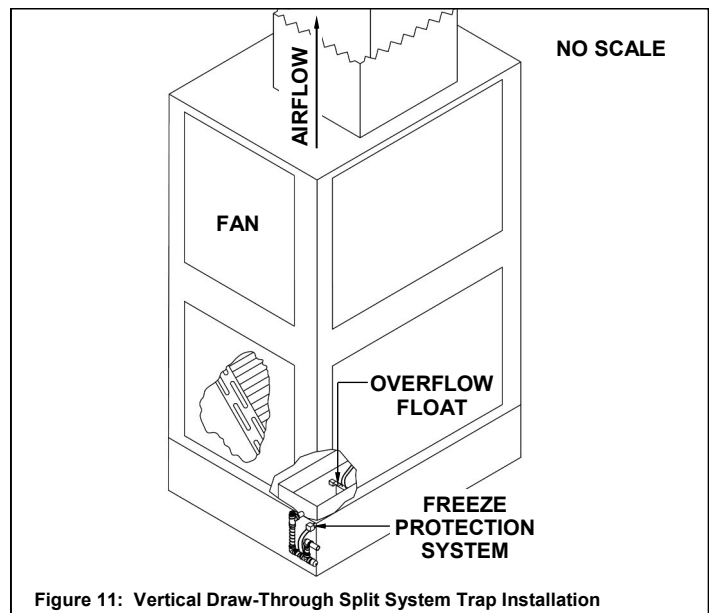

Figure 11: Vertical Draw-Through Split System Trap Installation

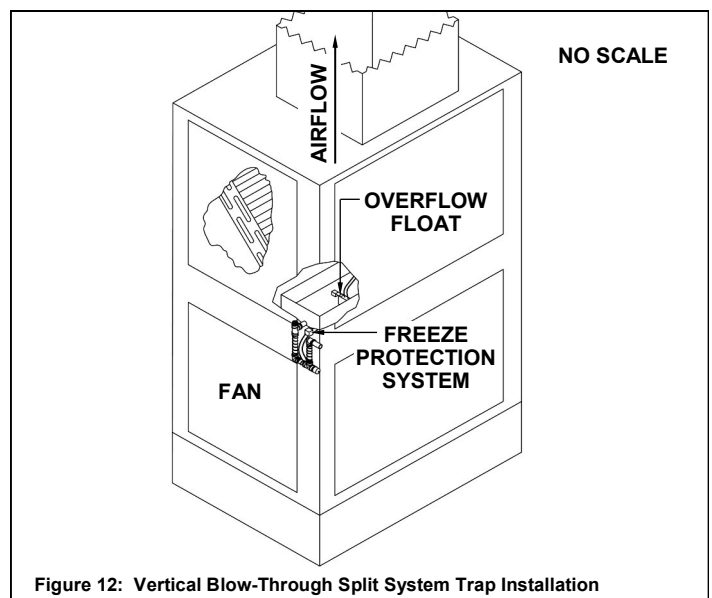

Figure 12: Vertical Blow-Through Split System Trap Installation